

G150

(15.0t x 0.75m)

The G150 can lift 15t at 0.75m while still boasting the flexibility of 180° rear hydraulic turning.



All Galizia models incorporate a full digital safe load indicator

Technical Specifications

Capacity	15t x 0.75m
Max height	11.4m (with searcher hook)
Max working radius	6m
Max lifting height	8.5m
Chassis dimensions	4375 (l) x 2180 (w) x 2470 (h) mm
Weight	12,800kg
Boom length	4.3 - 9.49m
Boom type	3 section hydraulic, box boom
Derricking angle	-5° to 47°
Steering	rear hydraulic 180°
Tyres	2 solid rear, 4 solid front
Diesel engine option	VM 4 cylinder Turbo or Yanmar
Fuel	diesel
Max output	62kW
Tank capacity	80 litres
Travel speed	12km/h
Electric power option	16kW
Power source	80v rechargeable battery
Travel speed	7km/h



Standard Equipment

Digital safe load indicator with display, proportional distributor joystick-controlled, audio-visual overload alarm, reversing alarm, seat and seatbelt sensor, overload warning lamps

Optional Equipment

Searcher hook, hydraulically extending searcher hook, full winch system, auto-levelling telehandler forks, low marking tyres

Elevations

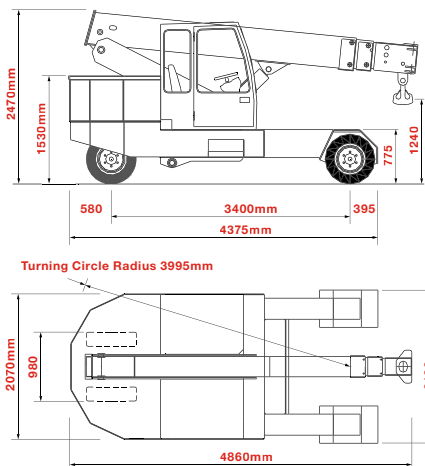

Rated Loads

